

## 1. Motivation and objectives

Run-of-river hydropower plants (HPPs) disrupt fish migration routes decimating fish populations worldwide. While various technologies for the fish upstream migration technologies are well developed, there is still a lack of knowledge on downstream fish passage technologies with regard to fish species, hydraulic conditions and operational issues at HPPs.

The main goal of this research study is to develop a fish protection and guidance technology for downstream migrating fish with minimum impact on power plant production or operation. The focus lies on fish guidance systems with vertical bars (i.e. louvers and angled bar racks) for large HPPs with design discharges above 100 m<sup>3</sup>/s (Fig. 1). The present study contributes to a fish-friendly and sustainable usage of hydropower.



Fig. 1: Fish guidance structure with bypass at a run-of-river HPP

## 2. Fish guidance structures with innovative bar design

Although modified bar racks (MBR) developed based on louver design provide high fish guidance efficiency (Kriewitz, 2015), they still negatively impact HPP production due to high head losses and poor admission flow quality. To mitigate these negative effects an innovative curved bar design was developed (Fig. 2). In the present study, these so-called *modified curved-bar racks* (MCR) are studied with regard to hydraulic conditions and fish guidance.

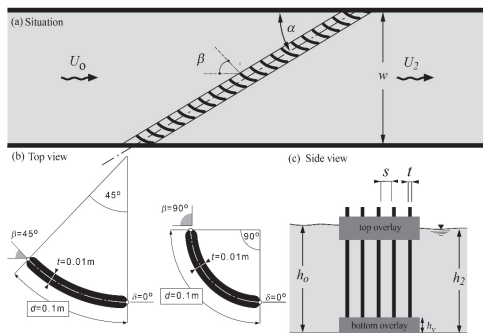

Fig. 2: Geometric and hydraulic rack parameters of modified curved-bar racks (a) rack top view, (b) bar shape top view, (c) side view

## 3. Research plan

To meet the objectives, different models are set up (Fig. 3). The effects of main rack angle, bar angle, bar spacing, bar depth and top or/and bottom overlays on the hydraulic head losses and flow fields at MCRs are studied in a 1:2 scaled detailed model (cf. Fig. 2). Different bypass systems are developed and optimized with 1:1 scaled experiments. Fish guidance efficiencies (FGE) of the optimized MCR-bypass system are assessed with life-fish tests. Finally, operational issues such as large wood accumulation and sediment transport are investigated.

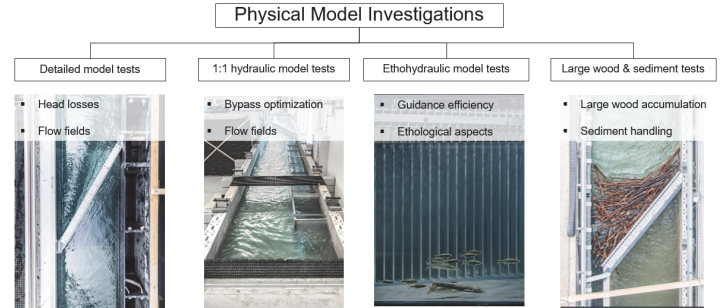

Fig. 3: Different model setups to optimize the design of FGS and bypass and maximize the FGE

## 4. First results

With the new bar shape, head losses are significantly reduced. The head losses of MCRs are up to 5.5 times lower than those for MBRs and are in the same range of  $0 \leq \xi_R \leq 3$  as for most trash racks used at Swiss hydropower plants (Meusburger, 2002). The bar angle  $\beta$  has the largest effect on head losses and the flow field as shown in Fig. 4. Upstream of the rack, flow velocities steadily increase up to  $1.25 U_0$  and  $1.85 U_0$  for  $\beta = 45^\circ$  and  $\beta = 90^\circ$ , respectively. The mild acceleration for  $\beta = 45^\circ$  is a good indication for a high FGE (Boes & Albayrak, 2017). Fig. 4a also shows the flow straightening effect of curved bars with  $\beta = 45^\circ$  resulting in a quasi-symmetrical velocity distribution downstream of the rack as compared to the low admission flow quality for  $\beta = 90^\circ$  (Fig. 4b). In the next step, the recommended MCR configuration with  $\alpha = 30^\circ$ ,  $\beta = 45^\circ$  and  $s = 50$  mm (Fig. 4a) will be tested in the 1:1 model and with live-fish experiments.

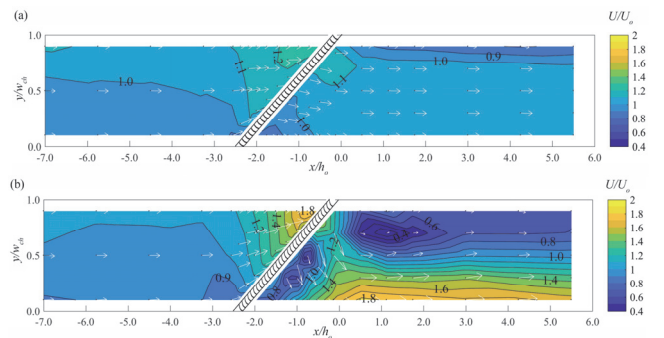

Fig. 4: Measured flow field of  $U/U_0$  at MCR configuration  $\alpha = 30^\circ$ ,  $s = 50$  mm (a)  $\beta = 45^\circ$  and (b)  $\beta = 90^\circ$ .

Given the highly reduced head losses and improved flow field, MCRs present a promising potential over louvers and MBRs for fish protection and guidance facilities at HPPs.

## 5. References

Kriewitz, C. R. (2015). Leitrechen an Fischabstiegsanlagen – Hydraulik und fischbiologische Effizienz (Guidance racks at fish passage facilities – Hydraulics and fish-biological efficiency). VAW-Mitteilung 230, R. M. Boes, ed., Laboratory of Hydraulics, Hydrology and Glaciology (VAW), ETH Zurich, Zürich, Switzerland [in German]

Meusburger, H. (2002). Energieverluste an Einlaufrechen von Flusskraftwerken (Head losses of trash racks at run-of-river hydropower plants). VAW-Mitteilung 179, H.-E. Minor, ed., Laboratory of Hydraulics, Hydrology and Glaciology (VAW), ETH Zurich, Zürich, Switzerland [in German]

Boes R. M., Albayrak I. (2017). Fish guidance structures: New head loss formula and fish guidance efficiencies, Proceedings of the 37th IAHR World Congress, Kuala Lumpur, Malaysia